

AAAnalyst 600/800 atomic absorption spectrometers



maximum **performance** from
the **leader** in inorganic analysis

maximum AA

performance



The high-performance line of AAAnalyst™ atomic absorption (AA) spectrometers maximizes AA performance for even the most difficult samples. These systems generate superior results and provide faster, more accurate analyses. For over 40 years, PerkinElmer has been the leader in inorganic spectroscopy. With tens of thousands of AA spectrometers in operation worldwide, the name PerkinElmer is synonymous with performance, ease of use and reliability.

The AAAnalyst 600 and 800 systems offer top-of-the-line technology and exceptional performance. The AAAnalyst 600, a dedicated transversely heated graphite atomizer



(THGA™) system, offers the best in graphite furnace. With Zeeman background correction, the AAnalyst 600 exceeds the requirements of today's laboratories, whether analyzing difficult samples or for achieving the lowest detection levels.

For laboratories that need the best in both flame and THGA furnace, the AAnalyst 800 provides a fully-integrated benchtop system with superior performance to meet all inorganic analysis needs. Switching between flame and furnace is as simple as a click of the mouse and includes automatic alignment for optimum performance.

Other dual-system approaches not only require the purchase of two separate spectrometers, doubling the demand for bench space and the investment in lab facilities, but also require manual alignment.

The high light throughput optical system of the AAnalyst 600 and 800, combined with a solid-state detector, provides the highest quality efficiency and signal-to-noise performance of any AA system on the market. With the acclaimed WinLab32™ control software, the AAnalyst systems bring a new level of performance and ease of use to analysis and data reporting.

unprecedented performance for the most demanding

High-efficiency optical system for lowest detection limits

At the heart of these advanced AAnalyst systems is an exceptionally efficient optical system featuring a unique solid-state detector with a photoactive surface optimized to provide the highest quantum efficiency in the UV region. Combine our state-of-the-art detector with proven monochromator efficiency and spectrometer throughput, and even elements such as As and Ba can be measured with outstanding signal-to-noise ratios.

THGA furnace provides uniform temperature distribution

The patented THGA tube used in the AAnalyst systems provides a uniform temperature distribution along its entire length (Figure 1). This eliminates cooler temperatures at the tube ends and removes most interferences. With the THGA tube design, accuracy and sample throughput are improved by reducing the need for the time-consuming standard additions technique.

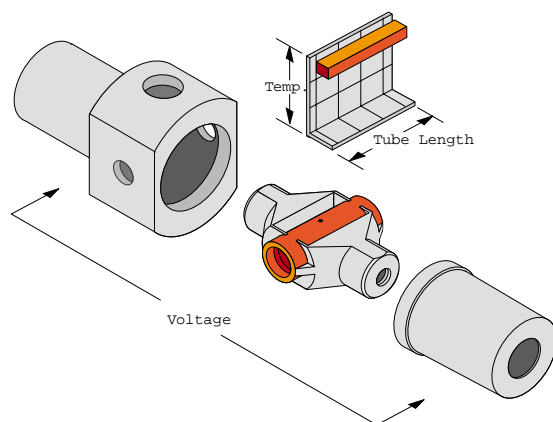

Figure 1. The THGA tube provides a uniform temperature profile.

Longitudinal Zeeman-effect background correction provides lowest detection limits

With longitudinal Zeeman-effect background correction, the amount of light throughput is doubled by eliminating the need for a polarizer in the optical system. All other commercial Zeeman designs incorporate inefficient polarizers that reduce light throughput and diminish performance. With this unique design, the AAnalyst systems provide the lowest detection levels available. To further improve detection levels and accuracy, the AAnalyst systems also include optimized sampling frequency and interpolated background correction.

Consistent temperature control enhances performance

In conventional furnace systems, the heating rate during atomization depends on the input-line voltage. As voltage varies from day to day, season to season or among laboratory locations, so does the heating rate. The AAnalyst high-performance systems use enhanced power control circuitry to maintain a uniform heating rate, so no matter where a system is located, you can be sure that it provides outstanding consistent performance.

Safety First

Safety features are of foremost importance in any flame AA spectrometer. The AAnalyst flame systems include sensors and interlocks to ensure the utmost in safety. Operation is permitted only if all conditions are satisfied for totally safe operation. Flame ignition and switchover from air-acetylene to nitrous oxide-acetylene are computer controlled and automatic. In the event of a power failure, the flame is extinguished safely and automatically.

applications

Real-time continuous measurement for unmatched flame stability

The revolutionary double-beam design of the AAnalyst 800 provides continuous simultaneous measurement of both sample and reference beams for flame measurement (Figure 2). Utilizing a high-efficiency fiber-optic cable, the sample and reference beams are simultaneously focused on the solid-state detector. This translates into increased signal integration time (without increasing analysis time) for improved detection limits and reproducibility.

Burner system maximizes stability

The PerkinElmer premix burner chamber has been proven in thousands of laboratories worldwide. The corrosion-resistant solid titanium burner head easily installs in the burner chamber, while a fail-safe mechanism ensures it is always properly restrained without the need for hold-down cables. An inert polymer spray chamber provides superior performance for corrosive and high-solids matrices. Manufactured from a high-strength composite, the spray chamber eliminates the need for pressure-relief devices. The high-precision nebulizer maximizes stability and sensitivity even for the toughest matrices. The nebulizer is adjustable so a wide variety of sample matrices—aqueous or organic, acids or bases, dilute or concentrated—can be analyzed under optimum conditions.

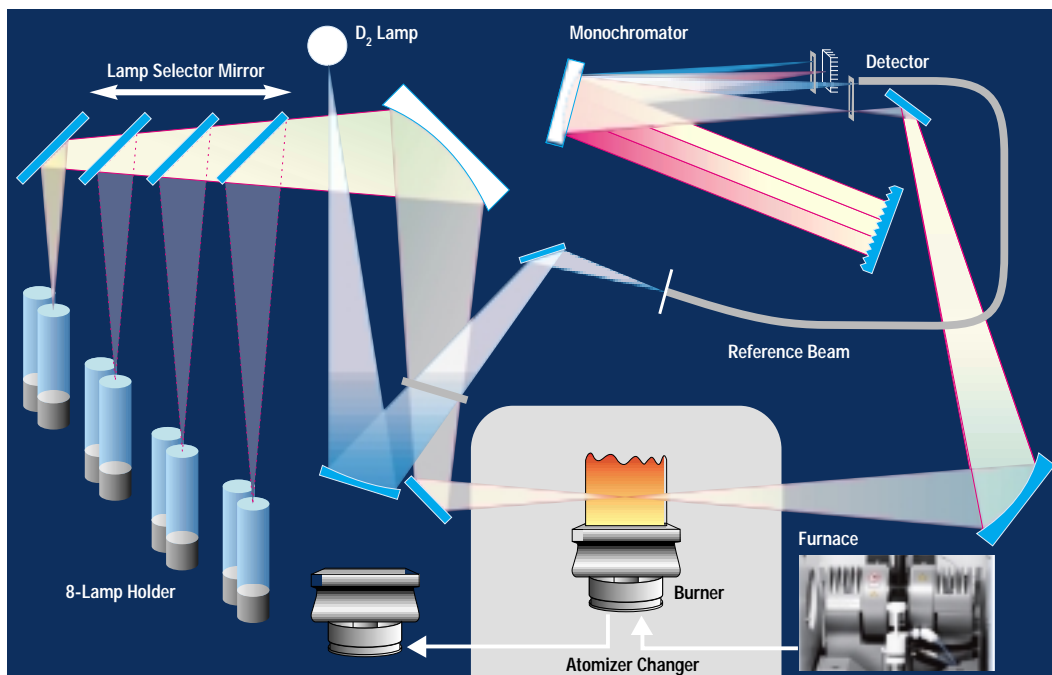

Figure 2. Revolutionary optical system for maximum performance.

easy to use for maximum productivity

The high-performance AAnalyst systems with automatic lamp selection and alignment make setup easier than ever thought possible. High-capacity autosamplers along with WinLab32 software bring a new level of productivity to the laboratory.

Automatic lamp selection and alignment ensure proper installation

The systems include an eight-lamp mount with built-in power supplies for both hollow cathode and electrodeless discharge lamps (EDLs) (Figure 3). EDLs provide much higher light output and longer lifetime when compared to conventional hollow cathode lamps. The patented PerkinElmer cableless Lumina™ lamps ensure proper connection. Just slide them in—you can't connect them incorrectly. The Lumina lamps are then recognized by the AAnalyst systems and the wavelength, slit and lamp parameters are automatically set and the lamps aligned.



Figure 3. Eight-lamp mount for maximum flexibility.

Switching between techniques has never been easier

A simple mouse click is all that is needed to change between flame and graphite furnace. Switching between flame and graphite furnace is computer controlled ensuring each atomizer is returned to its previously determined optimum position. Only the high-performance AAnalyst systems offer fully automated alignment of both the flame and furnace for optimized performance and day-to-day reproducibility.

Automated optimization for maximum sensitivity

Sensitivity and accuracy in flame AA are directly correlated to the optimization of the burner position as well as the gas flows (Figure 4). Careful optimization of these parameters, which can be different for each element, maximizes sensitivity and can significantly reduce or eliminate interferences. The unique computer-controlled motorized burner system and gas controls allow precise, automated adjustments. Since the WinLab32 software allows optimized burner position and gas flows to be stored with an element method, each element in a sequential multi-element run can be determined using its own optimized parameters.

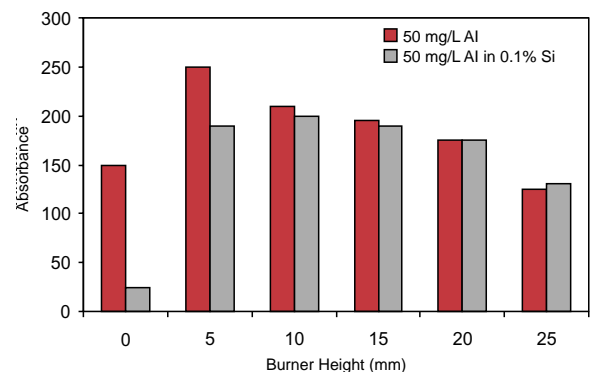

Figure 4. Optimizing burner height minimizes the interference of silicon on aluminum.

performance autosamplers

exceed your flame and furnace needs

Furnace autosampler ensures high throughput



Figure 5. The Furnace Autosampler easily swings into place.

The AS-800 Furnace Autosampler can accommodate up to 146 samples with true random sampling (Figure 5).

Digital micro-stepper, motor-

driven pumps provide unmatched accuracy and reproducibility. The autosampler completely automates calibration, reducing operator time and eliminating dilution errors. The autosampler can be easily programmed to automatically add spikes and matrix modifiers, perform multiple injections and dilute over-range samples. Solutions can be automatically injected into preheated tubes to optimize drying conditions and increase analysis speeds. Additionally, the AS-800 offers variable pipetting speeds to maximize reproducibility for viscous solutions.

STPF increases accuracy and productivity

More than 20 years ago, PerkinElmer pioneered the Stabilized Temperature Platform Furnace (STPF) technique to provide interference-free graphite furnace analyses. By eliminating the need for standard additions, STPF improves accuracy, precision and detection limits while dramatically improving sample throughput.

While some other instrumentation offers partial STPF implementation, the AAnalyst systems have fully implemented the technique, providing the best furnace performance.

Flame autosamplers offer exceptional sampling capacity

The AS-90*plus* or the AS-93*plus* Flame Autosamplers automate standard and sample introductions for instrument calibration and sample analysis, extending the capabilities of the AAnalyst 800 to those of a fully automated analytical workstation. Both PerkinElmer autosamplers come with a self-rinsing sampling probe and the flexibility to select from multiple tray configurations. An advanced drive system moves the sampling arm in the X and Y coordinates simultaneously, minimizing changeover time between samples (Figure 6). Random access gives you exceptional flexibility in the placement of samples and reference solutions. Corrosion-resistant sampling components are made entirely of acid- and solvent-resistant materials ensuring longer life. With the AS-93*plus*, a built-in peristaltic pump permits continuous rinsing of the sampling capillary between samples, significantly reducing the risk of carryover. In addition to the standard sample trays, the AS-93*plus* is compatible with trays from many 3rd-party suppliers providing increased flexibility.



Figure 6. AS-93*plus* autosampler for fully automated analysis.

AutoPrep 50 Automatic Dilution System

The AutoPrep 50™ system provides automatic, intelligent on-line dilution capabilities eliminating the time-consuming manual tasks in flame AA analysis. The AutoPrep 50 also eliminates problems such as carry-over and contamination. When used in conjunction with a PerkinElmer autosampler, the AutoPrep 50 provides fully automated sample introduction.

enhance productivity

with WinLab32 software

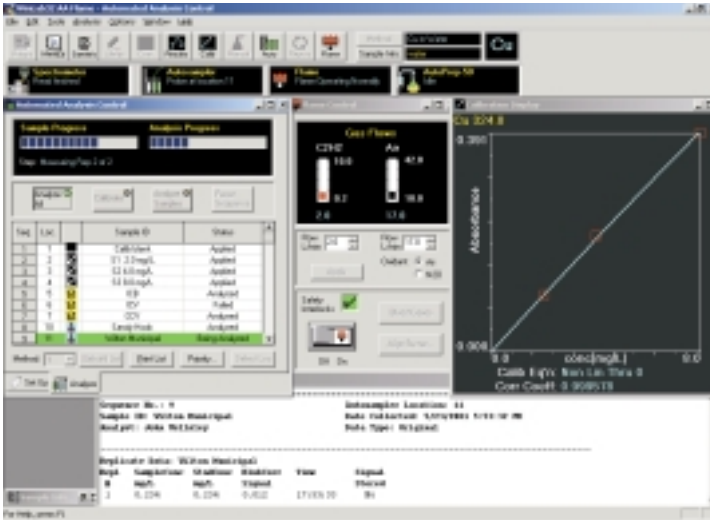

Figure 7. A suite of task-oriented windows can be displayed.

WinLab32 software combines ease of use and flexibility to bring a new level of productivity to your laboratory (Figure 7). Designed with extensive input from laboratory managers and AA users around the world, WinLab32 software provides all the tools and features needed to start running samples quickly and meet the requirements of today's laboratory.

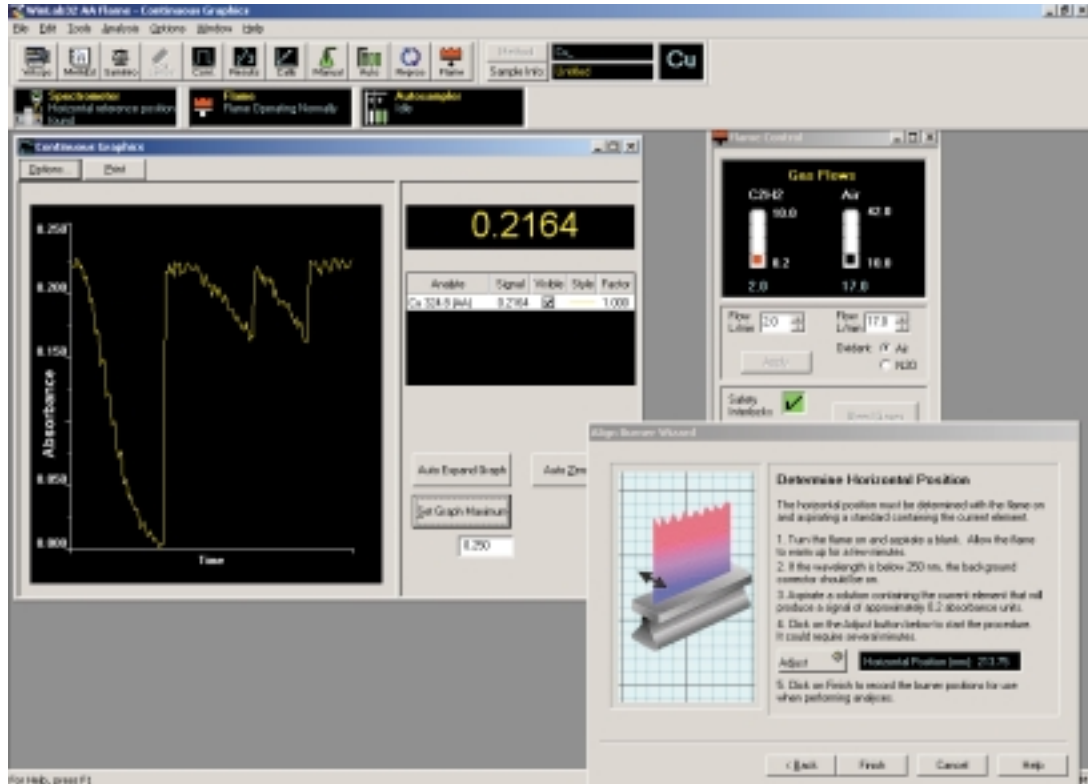

Figure 8. Wizards make complex tasks easy.

Easy to learn and easy to use

The extensive Wizard features of WinLab32 make complex tasks easy with step-by-step instructions (Figure 8). Tool Tips, available in six languages, provide additional information about screen text and entry fields. Status Panels display the status of each instrument component for easy monitoring. The Analysis List combines standard, sample and method information into one list showing the exact order the analysis will be run. This list also displays the analysis status at all times and can be printed as a summary at the end of the run.

Improved productivity

WinLab32 software improves laboratory productivity by reducing the time required for method development, sample analysis and report generation. Furnace method development is completely automated helping to optimize the pyrolysis and atomization temperatures as well as sample and modifier volumes (Figure 9). You can create methods, review or reprocess data offline, even add samples anytime during an analysis without interrupting the active analysis. Recall Calibration eliminates the need for initial calibration, while Edit Calibration gives you complete control over the quality of your calibration curve before you proceed with QC and sample analysis.

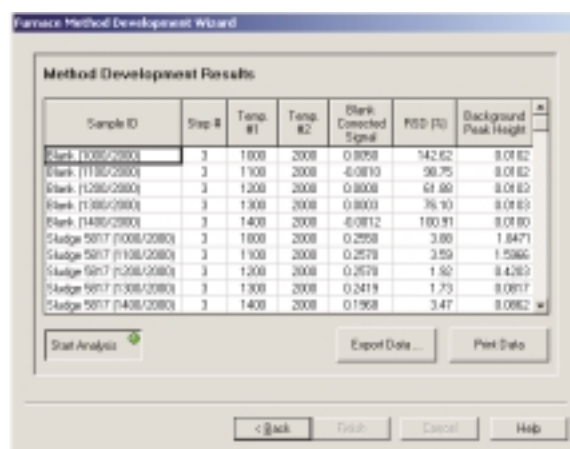
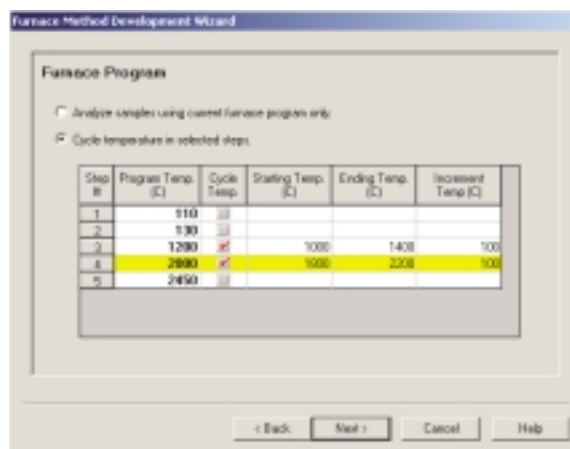
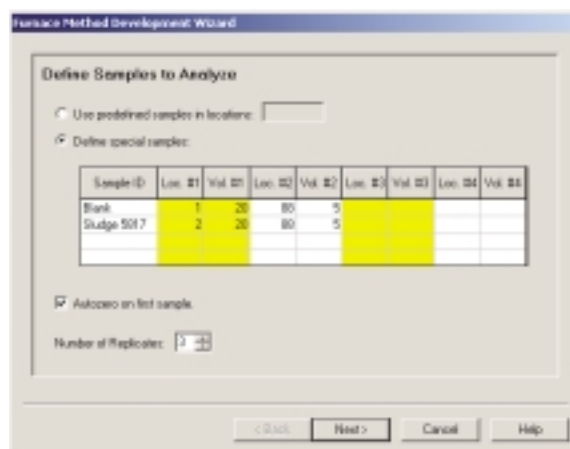

Figure 9. Method development is simplified using the Furnace Method Development wizard.

Easily work with data

Once you have performed an analysis, Winlab32 software makes it easy to work with your data in any way you wish. The Reporting wizard in Data Manager allows you to report and save data in a variety of formats compatible with commercial word processing and spreadsheet formats, even HTML (Figure 10). The Export wizard in Data Manager allows comma- (or other character-) delimited files to be created. You can also select and export data items describing the sample, mean values or replicate values from the Results Library. Peak profiles can be exported and read by most spreadsheet programs. Use a PerkinElmer LABWORKS LIMS system to create sample information files from backlog lists or QA batches and to store results.

Meeting regulated laboratory requirements

Many laboratories must comply with a variety of regulations imposed by government agencies or quality protocols and WinLab32 software helps your laboratory meet these regulations.

Leveraging the powerful security features of the Microsoft® Windows® operating system, WinLab32 software provides the protection your laboratory needs. With Winlab32 software, the administrator can define groups and assign permission levels by establishing password-controlled access. Once an analysis is completed, a copy of the method is stored with the results and the software even “signs” its data during storage. The Data Manager’s Verify Signature feature ensures that any alteration is readily detected. Reprocessing doesn’t change the stored data, but rather new data is written to the database with an appropriate notation.

The optional Enhanced Security (ES) software adds additional capabilities needed for regulatory requirements such as 21 CFR Part 11. Some of the regulatory features include the following:

- A Master Event Log records all actions performed by the user.
- Version numbers are added to all files and data sets.
- Options are provided to prevent analysis without data storage.

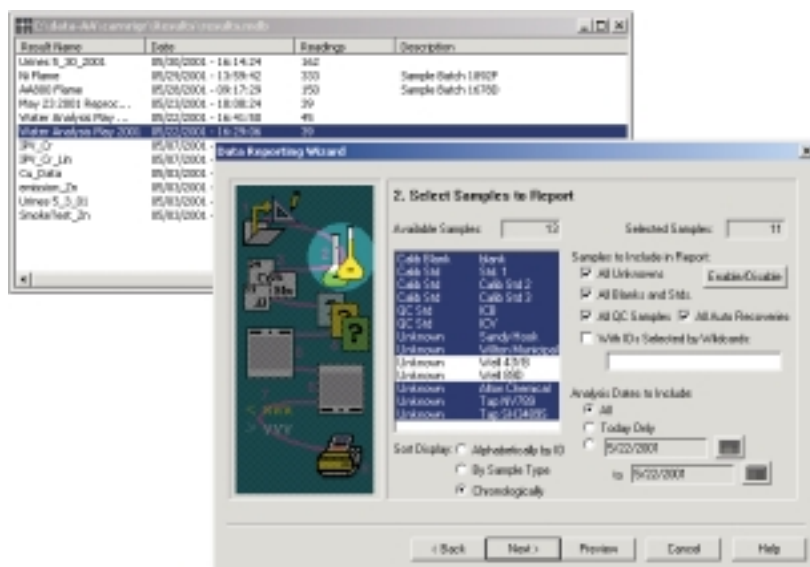

Figure 10. A suite of task-oriented windows can be displayed.

integrated solutions for a **variety** of applications

Based on over 40 years of experience in atomic spectroscopy, we understand your applications and also know the accessories required to meet your analytical needs. You can trust PerkinElmer, the leader in inorganic analysis, to provide you with the right tools for the job.

Mercury/Hydride Analysis Systems for improved detection limits

The MHS-15 Mercury/Hydride System can adapt your AAnalyst system for high-sensitivity determinations of Hg and hydride-forming elements such as As and Se. The MHS-15 offers detection limits down to the ng range, while minimizing capital investment and operating costs.

An optional automated flow injection based mercury/hydride system can also be added to the AAnalyst systems. These **Flow Injection Atomic Spectroscopy (FIAS™)** systems combine the advantages of mercury/hydride AA with those of flow injection thus providing true automation and exceptional detection limits even for sequential multi-element determinations (Figure 11).



Figure 11. FIAS 100 Flow Injection system with AS-91 Autosampler for improved detection limits.

FIAS-furnace coupling combines the large sample handling capability of a flow injection system with the sensitivity of the graphite furnace. This provides detection limits that are two to three orders of magnitude lower than those obtainable with conventional graphite furnace for hydride-forming elements such as As and Se and for Hg. With flow injection or continuous-flow sampling, you can analyze milliliters of sample instead of the normal microliter volumes typical for graphite furnace AA. Since the matrix is completely removed, the analysis is simplified.

Microwave Digestion System simplifies sample preparation

The Multiwave 3000® system is a versatile and powerful microwave sample preparation system that is easy to operate (Figure 12). Ideally suited for atomic spectroscopy techniques, the Multiwave simplifies sample preparation for all sample types, including foods, oils, plastics and environmental samples.



Figure 12. Multiwave 3000 for fast, easy sample preparation.

PerkinElmer, Inc.

PerkinElmer Instruments is part of the PerkinElmer, Inc. family, which also includes Optoelectronics and Life Sciences.

Expect MORE from the LEADER in atomic absorption

With over 40 years experience and a product line that includes flame AA systems, high-performance graphite furnace AA systems, flexible ICP-OES systems, and the most powerful ICP-MS systems; PerkinElmer is the undisputed leader in inorganic analysis. We have placed over 40,000 systems throughout the world, performing inorganic analyses every hour of every day. With the largest technical service and support staff in the industry and a solid reputation for quality products and service, the AAnalyst 600/800 high-performance Atomic Absorption spectrometers deliver the maximum in performance.

Whatever you're looking for, we've got it

PerkinElmer Instruments is a world leader in chemical analysis. Our Analytical Instrument technologies serve the fast-evolving pharmaceutical, chemical, environmental and semiconductor

industries, providing integrated solutions—from sample handling to interpretation and communication of test results.

As one of the best-known brands in research, analysis and testing, ours was probably the first analytical instrument you ever used. In addition to our AA systems, we offer a broad range of solutions in Luminescence, UV-Vis, NIR, GC, GC/MS, MALDI-TOF MS, HPLC, ICP, ICP-MS, Thermal Analysis, FTIR and LIMS. There are over 60 years of experience built into every product we make. So, for leading edge R&D and demanding QA/QC, you get the speed, accuracy and reliability you seek—for the productivity you need.

Our service and support people are located in 125 countries throughout the world and are factory trained. Compliance doesn't get any easier than with our software, including 21 CFR Part 11 technical compliance on many products. And online consumables and accessories ordering lets you get your hands on what you need fast.

PerkinElmer Instruments
710 Bridgeport Avenue
Shelton, CT 06484-4794 USA
Phone: (800) 762-4000 or
(+1) 203-925-4600
www.perkinelmer.com/instruments



©2002 PerkinElmer, Inc. All rights reserved. PerkinElmer is a trademark of PerkinElmer, Inc. AAnalyst, Lumina, WinLab32, THGA, FIAS and Autoprep 50 are trademarks of PerkinElmer Instruments LLC. Multiwave 3000 is a registered trademark of Anton Paar. Microsoft and Windows are registered trademarks of Microsoft Corporation. PerkinElmer reserves the right to change this brochure at any time and disclaims liability for editorial, pictorial, or typographical errors.