

FIAS Flow Injection for Atomic Spectroscopy



expanding laboratory productivity
and capabilities

increase productivity on PerkinElmer AA, ICP-OES or ICP-MS systems

Sample handling is an important aspect of any successful trace elemental analysis. On-line procedures for sample preparation and delivery are increasingly becoming methods of choice as the demands for productivity increase. Flow injection atomic spectroscopy (FIAS) is a superb complement to PerkinElmer® atomic absorption (AA), inductively coupled plasma optical emission spectroscopy (ICP-OES) or inductively coupled plasma mass spectrometry (ICP-MS) systems as a means of sample preparation and delivery. A fully integrated and automated system, the FIAS can dramatically increase laboratory productivity and capability.

What is flow injection?

Flow injection refers to the process of using a valve and pump assembly to inject small portions of sample into a stream of carrier solution. This schematic shows a sample slug being inserted into a moving carrier stream.

In the example below, a reagent is also inserted into the stream, which will be mixed with the sample to perform a type of sample pre-treatment (e.g., hydride generation).

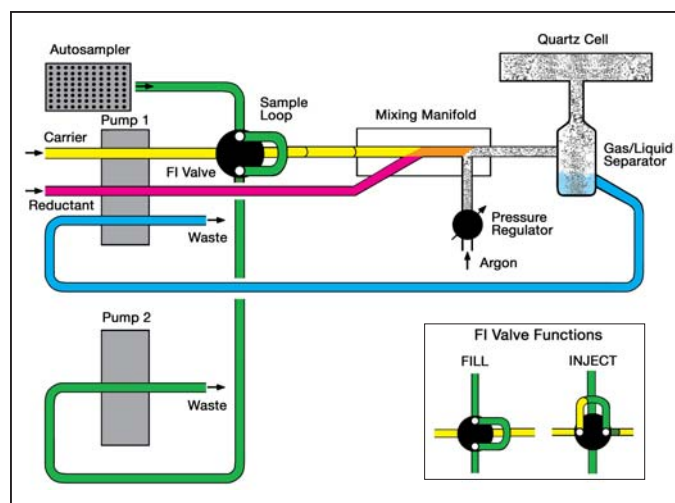
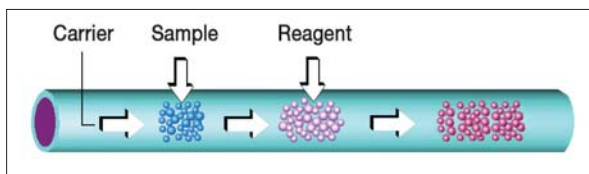

Figure 1. Schematic diagram of FIAS-400 system for automated hydride generation.

Flow injection can be used in a variety of ways to enhance the productivity of your laboratory, including:

- Automated hydride generation and amalgamation for improved detection limits for hydride-forming elements and mercury
- Analyte preconcentration or matrix removal for improved detection limits in difficult samples
- On-line addition of sample additives and internal standards for reduced sample-preparation time
- Sample pipelining to reduce washout times and improve stability for high-concentration samples

fully **automatic** flow injection for **improved** detection limits

Hydride generation

Flow injection (FI) fully automates mercury/hydride procedures, even for sequential multielement determinations.

The FIAS-100 and FIAS-400 systems can perform up to 180 individual determinations per hour in the FI-MHS (Mercury Hydride System) operating mode. For fully automated analyses, an optional autosampler can hold up to 270 samples and analyze them in any desired sequence. All that has to be done is to program the necessary parameters using either the WinLab32™ software for AA or ICP-OES detection or the ELAN® software for ICP-MS detection. While in the automatic mode, the system monitors and controls the entire process.

The analytical performance of the FIAS systems is exceptional compared to flame AA analysis without hydride generation, as is shown by the detection limits in Table 1. Equally impressive is the performance of the FI-mercury/hydride technique for the analysis of samples with complex matrices. As the element to be determined is separated from the sample matrix, measurement takes place practically free of matrix interference and nonspecific absorption.

Table 1. Detection Limits (µg/L) Using Flame and Hydride Generation AA.

Element	Hydride AA*	Flame AA
As	0.03	150
Bi	0.03	30
Sb	0.15	45
Se	0.03	100
Sn	0.10	150
Te	0.03	30

* 500 µL of solution

Mercury

Although mercury determination can be combined with other elements in an ICP-OES or ICP-MS analysis, it is typically measured in a dedicated analysis using mercury cold-vapor generation and AA detection. The FIAS system coupled with AA detection and the dedicated FIMS mercury system both provide detection limits compliant with regulatory methods (see Table 2). Coupled with amalgamation preconcentration, detection limits of 0.2 ppt mercury can be achieved using flow injection.

Benefits of flow injection mercury/hydride analysis

- Full automation yields high sample throughput
- Reduced reagent and carrier gas consumption for lower operating costs
- Optional amalgamation accessory allows ultratrace mercury determinations
- NaBH₄ or SnCl₂ methodologies for mercury
- Lower memory effects improve throughput
- Significantly lower interferences provide accurate results

ultratrace mercury determinations

using AA, ICP-OES or ICP-MS

There are many options for measuring mercury – from direct measurement with other elements using a multi-element technique such as ICP-OES or ICP-MS to a dedicated cold-vapor analysis after preconcentration for the ultimate detection limits. Table 2 summarizes the detection limits that can be expected for mercury, using various techniques with and without preconcentration.

Amalgamation provides ultratrace Hg detection

Mercury detection limits can be significantly improved using the automated amalgamation preconcentration accessory with the FIAS-100/400 or the dedicated FIMS mercury system. With this accessory, the atomic mercury vapor is collected on a fine gold/platinum gauze.



Figure 2. FIMS with Hg amalgamation.

After the collection period, all of the deposited mercury is released by rapid heating of the gauze and delivered to the desired detection technique – AA, ICP-OES or ICP-MS.

The detection limits obtained with multi-element ICP-MS or cold-vapor generation are well under the current maximum allowable limits for mercury in drinking water set by regulatory agencies such as the U. S. Environmental Protection Agency. Amalgamation preconcentration extends the measurement range to include ambient water levels, which are useful for natural background measurements and important for monitoring wastewater discharge into sensitive waterways.

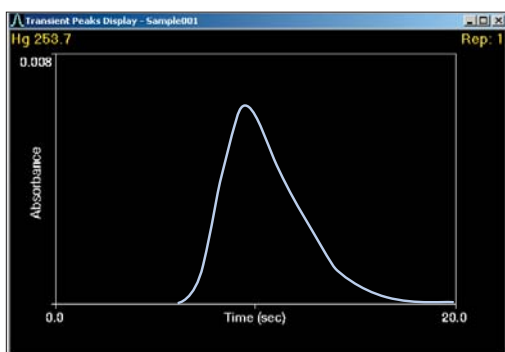

Figure 3. Signal from 10 ng/L mercury standard with amalgamation preconcentration.

Table 2. Mercury Detection Limits with Different Techniques.

Technique	Flow Injection	Preconcentration	Detection Limit, ng/L	Sample Volume
AA	FIAS	No	100	0.5 mL
	FIAS-continuous flow	Yes	10	5 mL
	FIMS	No	4	0.5 mL
	FIAS-graphite tube	Yes	0.5	100 mL
	FIMS-continuous flow	Yes	0.2	20 mL
ICP-OES	None	No	1000	–
ICP-MS	None	No	200	–
	FIAS-continuous flow	Yes	0.2	25 mL

FIAS-furnace for GFAA hydride analysis

FIAS-furnace coupling

Combining the benefits of flow injection with the excellent sensitivity of graphite furnace provides additional performance and sample-handling capability.

Graphite furnace AA is one of the most sensitive techniques for trace metal determinations. However, with this technique, detection limits are constrained by the limited sample-volume capacity (typically 10 to 50 μL). This prevents the determination of ultratrace analyte concentrations in some samples. In such cases, time-consuming preconcentration procedures, or more expensive analytical techniques such as ICP-MS, are required.

With flow-injection or continuous-flow FIAS, hydride-forming elements or Hg can be concentrated in the graphite furnace using several milliliters of sample. Thus, detection limits are improved by 2 orders of magnitude (100 fold) or more (Table 3).

In addition, since the analyte elements are removed from the sample matrix, chemical and background absorption interferences are virtually eliminated, improving analytical accuracy.

Table 3. Detection Limits for Aqueous Solutions Using Graphite Furnace and FIAS-furnace Coupling.

Element	Detection Limit ($\mu\text{g/L}$)	
	Graphite Furnace*	FIAS-Furnace**
As	0.13	0.002
Bi	0.13	0.003
Ge	0.13	0.010
Sb	0.13	0.003
Se	0.13	0.001
Sn	0.25	0.006
Te	0.25	0.003

* 20 μL sample volume

** 5 mL sample volume

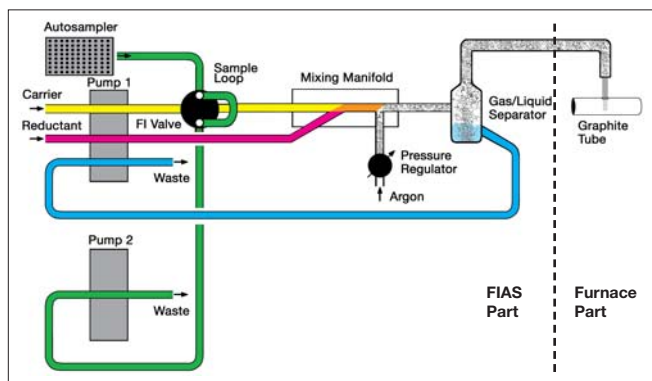

Figure 4. Schematic diagram of FIAS-furnace setup.

Benefits of FIAS-furnace coupling for the determination of hydride-forming elements

- Detection limits improved 100 fold or more
- Elimination of chemical and background interferences
- Fully automated operation improves productivity
- Eliminates time-consuming preconcentration techniques
- Cost-effective solution for ultratrace determinations

increase your lab flexibility with FIAS for AA, ICP-OES or ICP-MS

Flow injection represents one of the most flexible and efficient means of sample handling and delivery, offering several advantages for your AA, ICP-OES or ICP-MS system. Plus, the system has been fully integrated with WinLab32 for AA and ICP and the ELAN ICP-MS software.

Flow-injection analysis is ideally suited for samples containing high levels of dissolved solids. For example, saturated salt solutions or dissolved fusion mixtures can be directly analyzed for extended periods (Figures 5 and 6). Since the system is continuously rinsed with the carrier stream after each sample measurement, there is reduced danger of blocking the nebulizer or burner slot in AA or depositing material on ICP-MS cones. This maximizes instrument stability and reduces the time required to perform recalibration and maintenance. This type of sample pipelining is also important when a high concentration of the analyte is present, reducing washout times.

Smaller samples (as small as 50 μL) can be used with flow injection, reducing the consumption of valuable or limited sample volumes. Low sample consumption is also beneficial for routine analysis. For example, with fully automated sequential multielement analysis, more determinations can be performed with a given volume of sample.

Sample preconcentration or matrix removal can be achieved by adding a small column to the flow path. Binary separations of elements may also be achieved in combination with the choice of adsorbent and eluents. This is useful for inorganic speciation of two components or a binary separation of, for example, inorganic versus organic forms of an element.

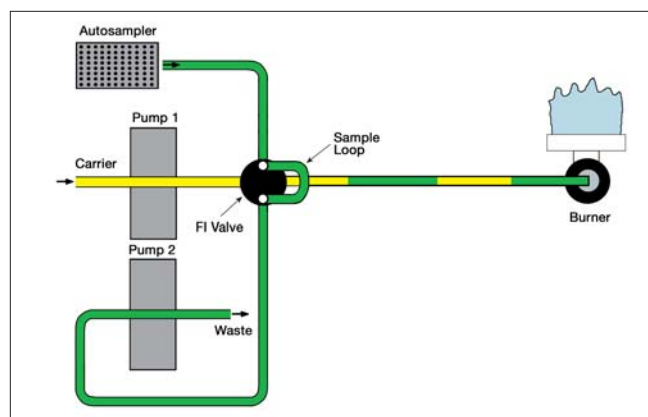

Figure 5. FIAS-400 flow schematic.

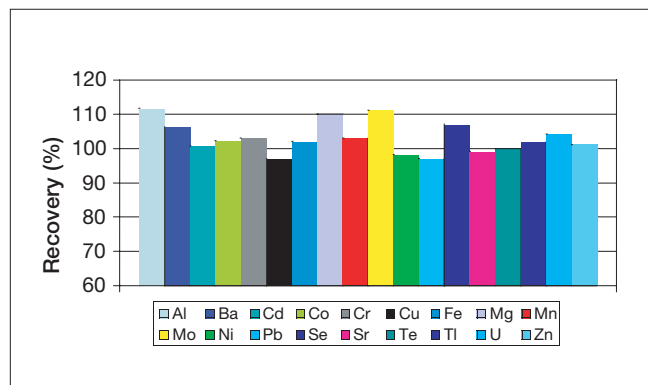

Figure 6. Recovery for 10 $\mu\text{g/L}$ multielement spike in 0.1% CaCl_2 using FIAS-ICP-MS.

Benefits of FIAS with AA, ICP-OES and ICP-MS

- Higher tolerance for complex sample matrices
- Faster washout of high-concentration analytes
- Lower sample consumption
- Analyte preconcentration/matrix removal
- Closed system reduces contamination

FIAS-100/400 Systems

System description	Automated flow injection system for use with Flame AA, cold-vapor and hydride-generation AA, graphite furnace AA, ICP-OES and ICP-MS systems. The FIAS-100 system is provided with 1 pump and the FIAS-400 systems are provided with 2 pumps.
System control and samples	Fully automated operation with computer-controlled spectrometer systems through control windows integrated into PerkinElmer instrument-control software.
Transport of reagents	Stepper-motor driven peristaltic pump(s) with a maximum of 8 channels each for tubing with 0.13 to 3.18 mm inner diameter. Pump speed is selectable from 20 to 120 rpm.
Sampling and flow switching	FI switching valve with 5 ports and exchangeable sample loops. An optional 8-port valve is available for the FIAS-400MS system. All systems have exchangeable sample loops of various volumes.
Gas supply	Carrier gas stream (argon) flow controlled from 40 to 250 mL/min by flow meter. Required inlet pressure: 320-400 kPa. Automatic switch-off after operating pauses of more than 10 min.
Absorption cell	Quartz cell is required for mercury/hydride AA analysis.
Cell heating	The cell can be heated using the air/acetylene flame or an optional electrically heated mantle (100 to 1000 °C).
Data connection	Built-in IEEE-488 and RS-232C interfaces. Addressing and switchover between IEEE and RS-232C by DIP switches.
Power requirements	115 VAC or 230 VAC $\pm 10\%$, 50/60 Hz $\pm 1\%$, 750 VA maximum.
Regulatory compliance	Classified as a laboratory instrument. Complies with the applicable European Union directives and standards for safety and electromagnetic compatibility for CE marking. The instrument has been developed and is produced in compliance with ISO 9001.
Weight	11.2 kg.
Dimensions (WxHxD)	42 cm x 18 cm x 41 cm (including sample tray).

Amalgamation Accessory

Principle	Amalgamation of mercury on a gold/platinum gauze and fast release of mercury by heating the gauze using an infrared heat source.
Heating temperature	Approximately 600 °C.
Cooling	By means of a flow of compressed air.
Carrier gas flow	75 or 300 mL/min.
Operation	Collection, heating, cooling and flushing times are programmed in the FIAS software.
Power requirements	100/120/200/220/230/240 VAC $\pm 10\%$, 50/60 Hz $\pm 1\%$, 325 VA maximum.
Weight	4.9 kg.
Dimensions (WxHxD)	25 cm x 25 cm x 24 cm.

PerkinElmer, Inc.

Expect more from the leader in inorganic analysis

With over 40 years experience and a product line that includes flame AA systems, high-performance graphite furnace AA systems, flexible ICP-OES systems and the most powerful ICP-MS systems, PerkinElmer is the undisputed leader in inorganic analysis. We have placed over 40,000 systems throughout the world, performing inorganic analyses every hour of every day. With the largest technical service and support staff in the industry and a solid reputation for quality products and service, the FIAS accessory delivers solutions for your most demanding throughput needs.

Whatever you're looking for, we've got it

PerkinElmer is a world leader in chemical analysis. Our analytical-instrument technologies serve the fast-evolving pharmaceutical, chemical, environmental, forensics and semiconductor industries, providing integrated solutions — from sample handling and analysis to communication of test results.

As one of the best known brands in research and testing, ours was probably the first analytical instrument you ever used. In addition to our atomic spectroscopy systems, we offer a broad range of solutions in Luminescence, UV/Vis, NIR, GC, GC/MS, HPLC, Thermal Analysis, Elemental Analysis, FTIR and LIMS. There are over 60 years of experience built into every product we make. So, for leading-edge R&D and demanding QA/QC, you get the speed, accuracy and reliability you seek — for the productivity you need.

PerkinElmer Life and Analytical Sciences
710 Bridgeport Avenue
Shelton, CT 06484-4794 USA
Phone: (800) 762-4000 or
(+1) 203-925-4602
www.perkinelmer.com

OneSource Laboratory Services — comprehensive service and support for today's results-driven lab

As a world leader in analytical instrumentation, PerkinElmer is the right partner for your application needs. In concert with global distribution of instruments, turnkey systems and consumables, we provide factory-trained global service and support.

PerkinElmer's OneSourceSM Laboratory Services provides you with a comprehensive worldwide service offering that allows you to take care of business and set your sights on what matters most — results. With over 1000 professionals serving more than 125 countries worldwide, PerkinElmer is your single source for instrument care and repair, validation services, software and hardware upgrades, education and more.



For a complete listing of our global offices, visit www.perkinelmer.com/lasoffices

©2004 PerkinElmer, Inc. All rights reserved. The PerkinElmer logo and design are registered trademarks of PerkinElmer, Inc. WinLab32 is a trademark, OneSource is a service mark and PerkinElmer is a registered trademark of PerkinElmer, Inc. or its subsidiaries, in the United States and other countries. ELAN is a registered trademark of MDS Sciex, a division of MDS, Inc. All other trademarks not owned by PerkinElmer, Inc. or its subsidiaries that are depicted herein are the property of their respective owners. PerkinElmer reserves the right to change this document at any time without notice and disclaims liability for editorial, pictorial or typographical errors.